

## Accepted Manuscript

Non-destructive testing and assessment of a piping system with excessive vibration and recurrence crack issue: An industrial case study

Zhi Chao Ong, Hoe Cheng Eng, Siamak Noroozi

PII: S1350-6307(16)30665-3  
DOI: doi:[10.1016/j.engfailanal.2016.12.007](https://doi.org/10.1016/j.engfailanal.2016.12.007)  
Reference: EFA 2998

To appear in:

Received date: 26 September 2016  
Revised date: 12 December 2016  
Accepted date: 16 December 2016

Please cite this article as: Ong Zhi Chao, Eng Hoe Cheng, Noroozi Siamak, Non-destructive testing and assessment of a piping system with excessive vibration and recurrence crack issue: An industrial case study, (2016), doi:[10.1016/j.engfailanal.2016.12.007](https://doi.org/10.1016/j.engfailanal.2016.12.007)

This is a PDF file of an unedited manuscript that has been accepted for publication. As a service to our customers we are providing this early version of the manuscript. The manuscript will undergo copyediting, typesetting, and review of the resulting proof before it is published in its final form. Please note that during the production process errors may be discovered which could affect the content, and all legal disclaimers that apply to the journal pertain.



# Non-destructive testing and assessment of a piping system with excessive vibration and recurrence crack issue: an industrial case study

## Corresponding author

Ong Zhi Chao (Z.C. ONG)

*Mechanical Engineering Department, Engineering Faculty, University of Malaya*

## Mailing address

*Mechanical Engineering Department, Engineering Faculty, University of Malaya, 50603 Kuala Lumpur, MALAYSIA.*

## Phone no.

*(+603) 79676815; (+6012) 4192911*

## Fax no.

*(+603) 79675317*

## Email address

*zhichao83@gmail.com; alexongzc@um.edu.my*

## Co-authors

Eng Hoe Cheng (H.C. Eng)

*Quadrant 2 Technologies Sdn. Bhd., Kuala Lumpur, MALAYSIA*

Siamak Noroozi (S. Noroozi)

*Department of Design and Engineering, Faculty of Science and Technology, Bournemouth University, Talbot Campus, Fern Barrow, Poole, Dorset, BH12 5BB, UK*

## Non-destructive testing and assessment of a piping system with excessive vibration and recurrence crack issue: an industrial case study

Z.C. Ong<sup>a\*</sup>, H.C. Eng<sup>b</sup>, S. Noroozi<sup>c</sup>

<sup>a</sup> *Mechanical Engineering Department, Faculty of Engineering, University of Malaya, 50603 Kuala Lumpur, MALAYSIA*

<sup>b</sup> *Quadrant 2 Technologies Sdn. Bhd., Kuala Lumpur, MALAYSIA*

<sup>c</sup> *Department of Design and Engineering, Faculty of Science and Technology, Bournemouth University, Talbot Campus, Fern Barrow, Poole, Dorset, BH12 5BB, UK*

### Abstract

Flow in piping generates random excitation which is non-periodic and that means resonance will not be the key factor to pipe failure. One of the main causes of pipe failure is weak supports. Due to their dissimilar stiffness in the piping system, it leads to low frequency and high amplitude flow induced vibration that causes high cyclic stress resulting in high cycle fatigue failure of the joints. Other contributing factors in pipe failure are poor or inadequate design, poor workmanship during installations or maintenance and inadequate or weak and flexible support. These pipes are usually required to work non-stop for 24 hours a day 7 days a week for weeks, months or years at a time. Regular monitoring and in-service dynamic analysis should ensure continuous and safe operation. This paper presents a case study on monitoring, diagnosis, and maintenance of a piping system. High vibration was observed during routine maintenance, in a 30 m high, 24 inch diameter amine pipes at an oil and gas processing plant in southern Thailand. Amine liquid leakage due to high cycle fatigue crack was reported at the piping bearing and this remained a major concern for the personnel at the plant. A non-destructive testing approach which relies on a combined experimental techniques (i.e. Operating Deflection Shapes (ODS)) and computational mechanics (i.e. Finite Element (FE) modal analysis, Computational Fluid Dynamics (CFD) Analysis, Fluid-Structure Interaction (FSI) Analysis) was used to assess the structural integrity of the piping and in the effort of proposing a suitable recommendation in rectifying the high vibration issue. The analyses concluded that the root cause of high vibration was due to inadequate and weak piping support. As a result, additional supports were proposed to counter the deflection of the piping generated by the flow. The supports were found effective in reducing vibration in which the stress concentration at the new supports and the piping was considered relatively low.

Keywords: Finite element analysis; Non-destructive testing; Pipeline failures; Structural integrity; Vibration

### 1. Introduction

Pipes are usually required to work non-stop for 24/7. Regular monitoring and in-service dynamic analysis should ensure continuous and safe operation. Generally, the fluid behaves as a turbulent flow and exerts random pressures on the wall of the pipe. Fluid-structure interaction, turbulent flow fluctuations, and unsteady pressure can induce a random excitation of the pipe and support structure

which often leads to high vibrations. High vibration in the piping is usually not related to resonance issue due to the nature of random excitation. One of the main causes of pipe failure is inadequate or weak and flexible support causing low frequency high amplitude flow induced vibration. This causes accelerated wear and tear especially near the joints due to their dissimilar stiffness resulting in high cycle fatigue failure of joints due to high cyclic stress caused by vibration [1]. It has been shown that the fluid-structure interaction phenomenon induces a significant dynamic response in the structure which affects the fluid forces acting on the inside walls of the pipes [2]. Other contributing factors in pipe failure are poor or inadequate design, poor workmanship during installations.

There are many case studies related to flow induced vibration of pipelines reported and reviewed [3, 4]. Some researchers developed analytical models in analysing piping vibration problem. Tian et al. established the pipeline vibration analysis model and the calculation method that includes the pressure pulsation parameters analytically. The reliability of the model and calculation method was verified with the field test data. The relationship between the intense vibration and gas pressure pulsation at the pipe elbow was studied and it was found that the coupling effect of pressure pulsation and pipeline system shall be considered in reflecting the actual vibration of the pipeline [5]. Zou et al. developed a state-variable model of reinforced composite natural gas filled pipelines for the analysis of flow induced vibration. The results of the analytical model were then validated by common Finite Element Analysis (FEA) [6]. Dai et al. used transfer matrix method which includes the steady combined force to formulate three-dimensional and curved pipelines conveying fluid. The vibration data in terms of natural frequencies, frequency response functions and instability were determined and analysed [7]. Researchers also utilised computational technique which involves FEA to investigate the high vibration problem in piping systems. Through this technique, computational simulations such as Computational Fluid Dynamics (CFD) analysis alone or combination of CFD and Fluid-Structure Interaction (FSI) analyses were performed to predict the pipe flow pattern, piping vibration and dynamic stress induced by flow. The simulation results were usually validated through experimental data. Ashrafzadeh et al. investigated the factors leading to the crack failure of high pressure gas pipe covered by split tee using FEA. The stress distribution caused by gas pressure inside the pipe was first investigated and Finite Element (FE) modal analysis was performed to study the structural dynamics of the piping system. It was found that by design an appropriate distance between supports and split tee, it could decrease the dynamic stress and the initiation and propagation of crack along the pipe could be inhibited [8]. Sierra-Espinosa and García analysed high vibrations in admission piping of a steam turbine. CFD analysis was performed and it revealed large steam flow instabilities produced by recirculation and high velocity exceeded a critical point. Based on CFD results, a pipe configuration was proposed in the effort of reducing the turbulence effects and subsequently led to reduction of vibration [9]. Zhang et al. investigated the structural vibration and fluid-borne noise induced by turbulent at the piping elbow and studied the effects of introducing guide vanes in reducing the vibration and flow induced noise. From the CFD analysis, it was found that putting a guide vane at the right location decreased uniformity of velocity distribution and pressure spectra and subsequently reduced the total vibration level and total sound power level at the piping elbow [10]. Majid et al. utilized CFD analysis to predict the failure of natural gas pipe. CFD was used to provide a greater understanding of the erosion behavior and the failure region indicated by the simulation results correspond well with the experimental study [11]. Zhu

et al. used a computational method which involves CFD and FSI analyses to investigate flow erosion and flow induced deformation of three-limb pipe used in oil transportation. The numerical results showed that the more severe flow erosion and greater deformation was observed especially at pipe bends [12]. Kong et al. investigated flow induced vibration problem of in-service duplex stainless steel piping system as well as the third party piping and drain valve system of an offshore gas processing platform. Vibration analysis was performed in identifying structural dynamics issue of the third party piping and drain valve system and the results showed that there was design problem due to dissimilar stiffness and dynamic incompatibility between the supplied pipe and valve systems [13]. By combining both experimental and computational techniques, flow -induced vibrations and maximum dynamic stresses were calculated and the highest flow rate for the piping system to run under the allowable endurance stress limit and safe condition was forecasted [14].

Experimental modal analysis (EMA) is a classical method for determining the dynamic behaviour of static structures in terms of their dynamic characteristics, e.g., natural frequency, damping and corresponding mode shape. The extracted modal parameters have been widely used in identifying the root cause of high vibration, detecting damages, validating finite element model and etc. For example, Rahman et al. conducted EMA to extract the dynamic characteristic of a 12-stage vertical pump to understand the dynamic behaviour of the pump and identify the root cause of high vibration [15]. Trebuña et al. also performed EMA on pipes of gas compressor stations to identify damages based on the shift of dynamic characteristics [16]. Liang et al. used EMA to validate the finite element model through correlating the dynamic characteristics [17]. The validated model was then used in vibration analysis and elimination of reciprocating compressor inlet pipelines. It must be noted that the classical EMA must always be performed on static structure or when the machine that is in 'shutdown' condition. This is because unaccounted force during operation can introduce misleading or erroneous results. Although extracting modal parameters while the system is in-service is not currently possible with EMA techniques but it is highly desirable, especially for a large and complex piping system that are required to be in-service 24/7 and stopping them can mean financial disaster in terms of loss revenue.

Another method of checking structures for signs of excess movement is commonly known as Operating Deflection Shape (ODS) analysis. This experimental technique is a non-invasive and non-destructive approach used to monitor the overall dynamics and the condition of a system while in operation [18-22]. It is useful when classical condition monitoring is not possible or when a full 3D visualisation of the dynamics of the motion is desirable. Rahman et al. conducted ODS analysis to determine the vibration or deflection pattern of a pump operating at a specific frequency [15]. However, the traditional ODS analysis used was insufficient to measure the dynamic characteristics of the system, because general rotating machines produce sinusoidal excitation, (i.e. a single frequency). Therefore two different techniques, i.e. EMA and ODS are commonly being deployed separately, and it is limiting their usage in certain applications.

In fact, random excitation by fluid flow in pipe creates a broadband excitation signature [23]. The broadband excitation by the flow will induce or excite all natural frequencies of the system within its frequency content/ bandwidth, hence the resulting vibration response will behave linearly proportional to the dynamic characteristics of the system. In other words, overlaid peak responses

identified by ODS analysis indicate the severity of vibration as well as natural frequency region, while vibration pattern in this peak frequency can be recognized as mode shape (i.e. deflection shape of a structure when resonance occurs).

This paper investigates the possibility of utilizing the broadband excitation characteristic of fluid flow to extract the dynamic characteristics of the piping system. In this way, the traditional ODS analysis can extend its capability to extract dynamic characteristics of an operating piping system, without performing EMA which requires stopping the process of the piping system. So, performing ODS analysis in this case could behave like the common output-only modal analysis, i.e. Operational Modal Analysis (OMA) which helps to reveal the natural modes of vibration in pipes. The proposed method gives high competitive advantage due to its time and cost effective approach. In this paper, the outcome of the application of non-destructive evaluation method for the vibration assessment and analysis of in-service pipes is also presented. This investigation is based on the combined application of experimental technique, i.e. ODS analysis and computational mechanics utilizing FEA, i.e. FE modal analysis, CFD analysis, FSI analysis and linear elastic stress analysis to assess the condition of an in-service pipe structure that is showing signs of excess movement due to excess flow induced vibration. With the computational technique, Structural Design Modification (SDM) as discussed in Rahman et al. and Norozzi et al. could be performed virtually prior to fabrication in proposing a suitable long-term solution to counter these excessive forces at the sources to ensure that the pipe operates under the allowable dynamic stress for a “theoretically infinite” life cycle [15, 24].

## 2. Problem Formulation

High vibration was observed during routine maintenance, in a 30 m high, 24 inch diameter amine pipes at an oil and gas processing plant in southern Thailand (Fig. 1). The processing pipe acts as a CO<sub>2</sub> removal unit where the transporting mediums consist of H<sub>2</sub>O, CO<sub>2</sub> and Methyl Diethanolamine (MDEA). The inlet, i.e. stream 216 is the liquid mixture of the mentioned three products where the outlet, i.e. stream 217 is a 2-phase mixture of vapor and liquid. The detailed operating parameters and mixture composition are tabulated in the mass balance table shown in Table 1.

In Aug 2008, amine liquid leakage due to high cycle fatigue crack was reported at the piping bearing. Though the crack line issue was resolved, the pipe is still showing excessive high vibration level and it remains a major problem to be resolved. Fail to do that will, in the long term, result in more vibration induced fatigue cracks.

This case study focused on the investigation of the root cause of high vibration recorded on the amine pipe which has caused the pipe crack and amine liquid leakage through a hybrid non-destructive testing and assessment approach.



Fig. 1: Amine pipe and stripper

Table 1: Mass balance table

Stream	216	217	217V	217L
Vapour Fraction	0.00	0.01	1.00	0.00
Temperature – °C	87	84	84	84
Pressure – barg	6.5	3.0	3.0	3.0
Mass Flow – kg/h	1326330	1326330	13353	1312970
Density – kg/m <sup>3</sup>	1067	365	6	1063
Molecular Weight	30	30	41	30
Viscosity – cP	1.22	1.30	0.02	1.30
Surface Tension – dyne/cm	40	41		41
Composition – mol.frac.				

CO <sub>2</sub>	0.0535	0.0535
MDEA	0.1045	0.1045
H <sub>2</sub> O	0.8420	0.8420

The hybrid non-destructive testing and assessment consist of experimental and computational analyses. The experimental analysis includes ODS analysis. This experimental technique is a non-invasive and non-destructive approach used to monitor the overall dynamics and the condition of a system while in operation. It is usually being used on a system under harmonics excitation to determine the system's vibration severity and deflection pattern. For the case of in-service piping, the flow generates random excitation to the pipe and random excitation by fluid flow in pipe creates a broadband excitation signature [23]. The broadband excitation by the flow will induce or excite all natural frequencies of the system within its frequency content/ bandwidth. Therefore, the traditional ODS analysis can extend its capability to extract dynamic characteristics of an in-service piping system, without performing the conventional EMA. So, ODS analysis in this case itself could behave like the common output-only modal analysis, i.e. OMA which helps to reveal the natural modes of vibration in pipes. ODS was carried out on-site while the pipe was in service and it was used to determine the vibration severity and deflection pattern of the amine pipes while in operation. Vibration measurements were taken on the amine pipe and stripper are as shown in Fig. 2. The measurement and evaluation procedure was devised using a state-of-the-art in-house data acquisition system based on a four-channel real-time dynamic signal analyser, a tri-axial and uni-axial accelerometers, and commercial modal analysis software, i.e. ME'scope (Vibrant Technology Inc, USA), to analyse the motion and the excessive vibration levels of the amine pipe. The test was performed with a uni-axial accelerometer as a reference input signal indicating the reference DOF and for the purpose of measuring the relative phase between accelerometers. The tri-axial accelerometer was used as a roving accelerometer and can measure acceleration in three orthogonal directions simultaneously. The roving accelerometer approach allows a large structure with multiple points to be investigated cheaply and effectively by passing the need to use many accelerometers simultaneously. The sampling rate used was 2048 samples/sec with a block size of 8192 samples. This yields better frequency resolutions of 0.25 Hz and 4 sec of time record length to capture every response signal. Ten averages were taken at each measurement point. The vibration signal was processed into the frequency domain, i.e. ODS Frequency Response Function (FRF) to assess the vibration severity and sent to ME'scope for post-processing to visualise the deflection shape during operation.

On the other hand, computational analyses which utilise FEA were carried out by first developing the FE model of the piping system using commercial FEA software, i.e. ANSYS. The FE model of the piping system was first built based on the piping design drawing and material listing provided by client. The dimensions of the pipe, stripper, piping supports were further validated through visual inspection at site. The meshing was generated with the built-in ICEM meshing module in commercial ANSYS software. For structural model mesh, hexahedron mesh type was used on the pipe while



tetrahedron mesh type was used on piping support and stripper. The mesh generated on the structural parts was 86,660 nodes and 42,661 elements. On the other hand, CFD domain mesh applies 0.15m of mesh size using sweep meshing method. This generated a total of 8,340 nodes and 6,371 elements. Grid independence test was conducted to validate the CFD result, i.e. pressure which will be used as input loading for structural analysis, i.e. FSI in latter stage. To ensure the reliability of the CFD loaded structural analysis results, the FE model was first validated through correlating the dynamic characteristics of the piping system between experimental, i.e. ODS/OMA and computational, i.e. FE Modal Analysis results. The close correlation of the two results indicates the FE model is assured and structural related analyses, i.e. deformation and stress in finite element analysis shall reflect the same in the actual system. Once a good model is achieved, further analyses such as CFD and FSI were performed computationally to investigate the flow pattern and its effect on pipe. As mentioned, the high vibration level on amine pipe is not related with resonance issue. Thus, the vibration problem may be a flow induced vibration issue. Steady state CFD analysis is needed to justify this assumption and it determines the total head (pressure) pattern generated by the flow which is then input as loading to structure in FSI analysis. Subsequently, FSI analysis gives the static deformation of the pipe. The total deformation shall be the superimposition of static deformation and dynamic deformation obtained from the ODS analysis. Moreover, stress analysis was performed on the structure to study its stress level. Based on these analyses, SDM were made computationally to reduce the vibration level and meanwhile to ensure that the stress level on the pipe, stripper, existing supports or newly proposed supports are within the allowable limit. SDM allows a large number of design modifications without having the unnecessary physical cycles of 'modify-and-test'. Conceptually, it is intended to save the unnecessary time and money by 'get-first-time-right' during fabrication. Upon obtaining positive results, the modification and fabrication are then performed on the real structure.

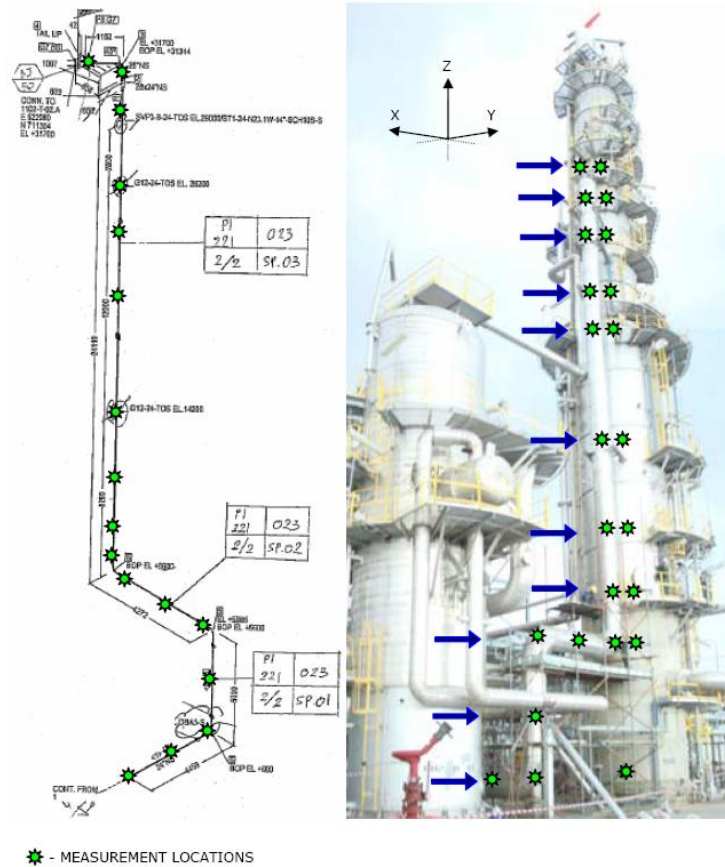

Fig. 2: Measurement locations for ODS on amine pipe and stripper

### 3. Results and discussions

#### 3.1. Vibration Assessment

The evaluation of whether or not the high vibrations represent a problem has to be based primarily on the vibratory stresses introduced into the piping. High vibration may not cause excessive stresses in the piping. However, it could cause excessive stresses to the fittings along the high vibration main piping system. Referring to Fig. 3, whenever piping vibration amplitudes at the measured frequencies are greater than the danger line, piping failures are typical occurrences. When vibration levels are below the design line, very few failure cases have occurred. Therefore, the vibration versus frequency criteria can serve as a good starting point in evaluating piping vibrations to screen those systems that need further analysis [25].

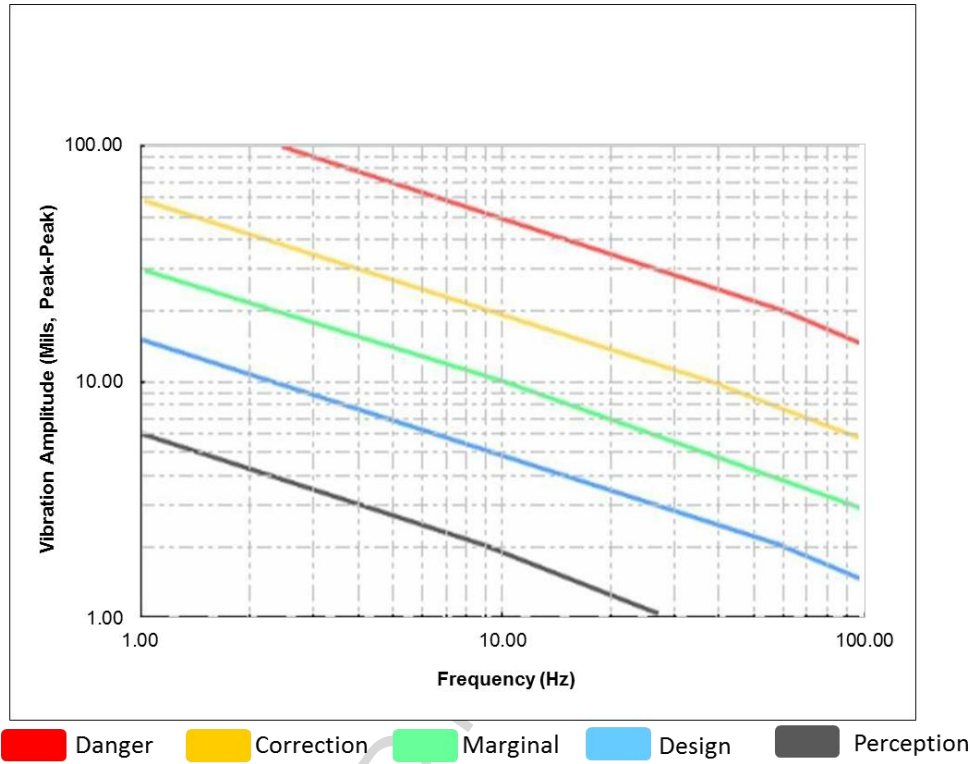

Fig. 3: Allowable piping vibration level versus frequency [25]

All the measured locations in X, Y and Z axes were plotted into the Allowable Piping Vibration Level (in mils peak to peak) versus Frequency for comparison. Fig. 4 shows the overlaid ODS spectral for amine pipeline. In general, vibration levels for amine pipeline are high and most of the vibration levels along the pipe exceed the Design line. Vibration level is near to Danger region for few measured locations. This might be due to improper pipe design which does not comply with OEM / API guideline. Furthermore, bends along the pipelines also may create acceleration head loss and line pulsations which induce high vibration.

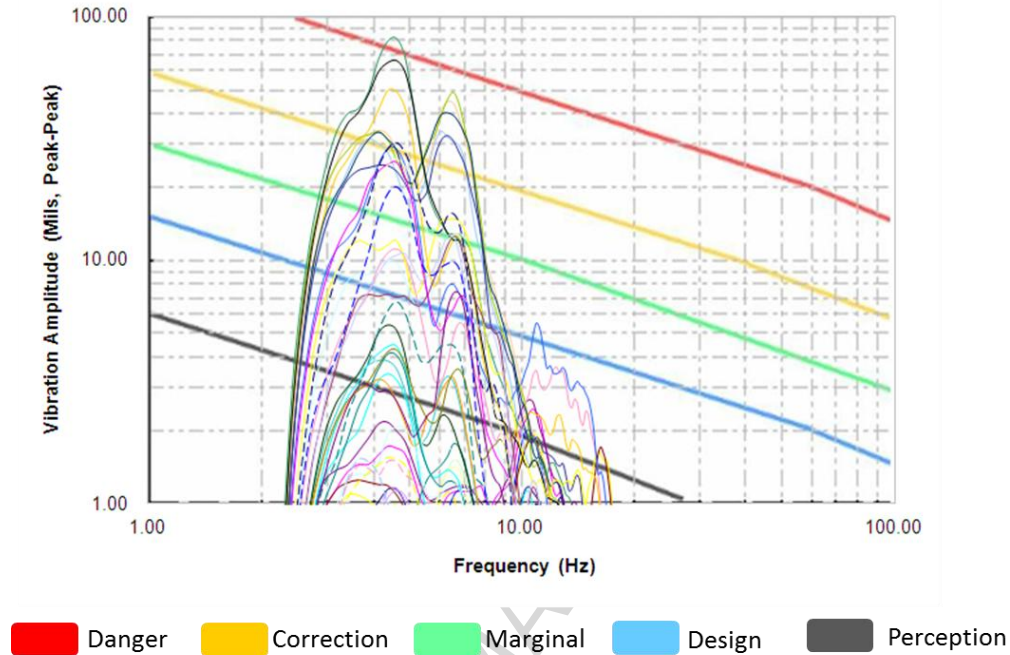

Fig. 4: Vibration assessment of in-service amine piping system

### 3.2. Operating Deflection Shape Analysis

ODS analysis is performed on amine pipe. ODS analysis performed dual tasks in this case study. First, it determines the vibration severity as well as the deflection shape of the piping system during operation. Secondly, due to random excitation behaviour from the flow, ODS could be used to extract dynamic characteristics of an in-service piping system like the common output-only modal analysis, i.e. OMA which helps to reveal the natural modes of vibration in pipes. Fig. 5 shows the overlaid ODS spectrum for amine pipe in displacement. It is noted that the maximum deflection recorded is at around 1mm. Fig. 6 shows the deflection pattern of the amine pipes while in operation. It is observed that the movement is dominated in Y-direction at 4.40 Hz and X-direction movement was dominant at 6.59 Hz. The peaks observed in ODS spectrum also reveals the vibration modes of the pipe which are the bending mode in Y and X directions at 4.40 Hz and 6.59 Hz respectively.

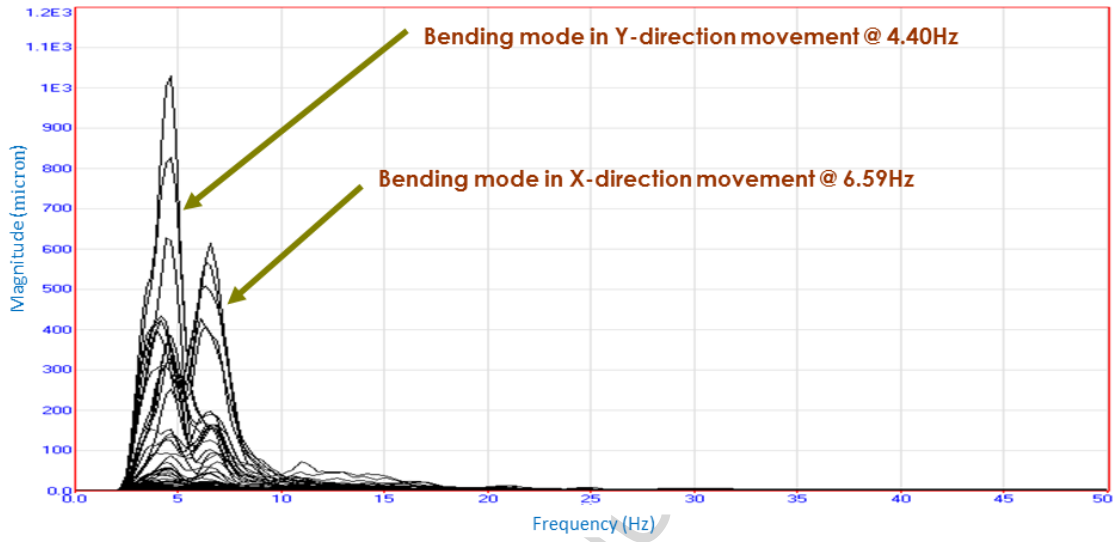
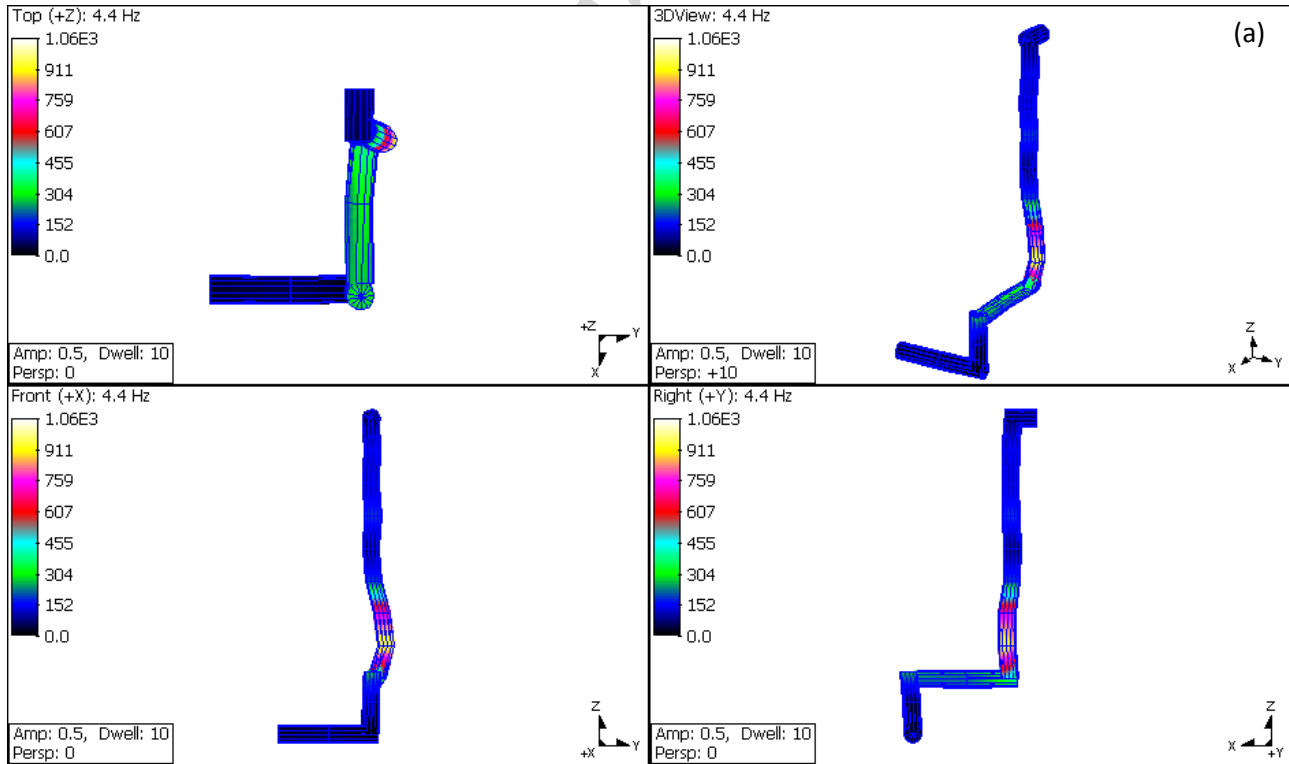

Fig. 5: ODS FRF of amine pipe in displacement (micron)



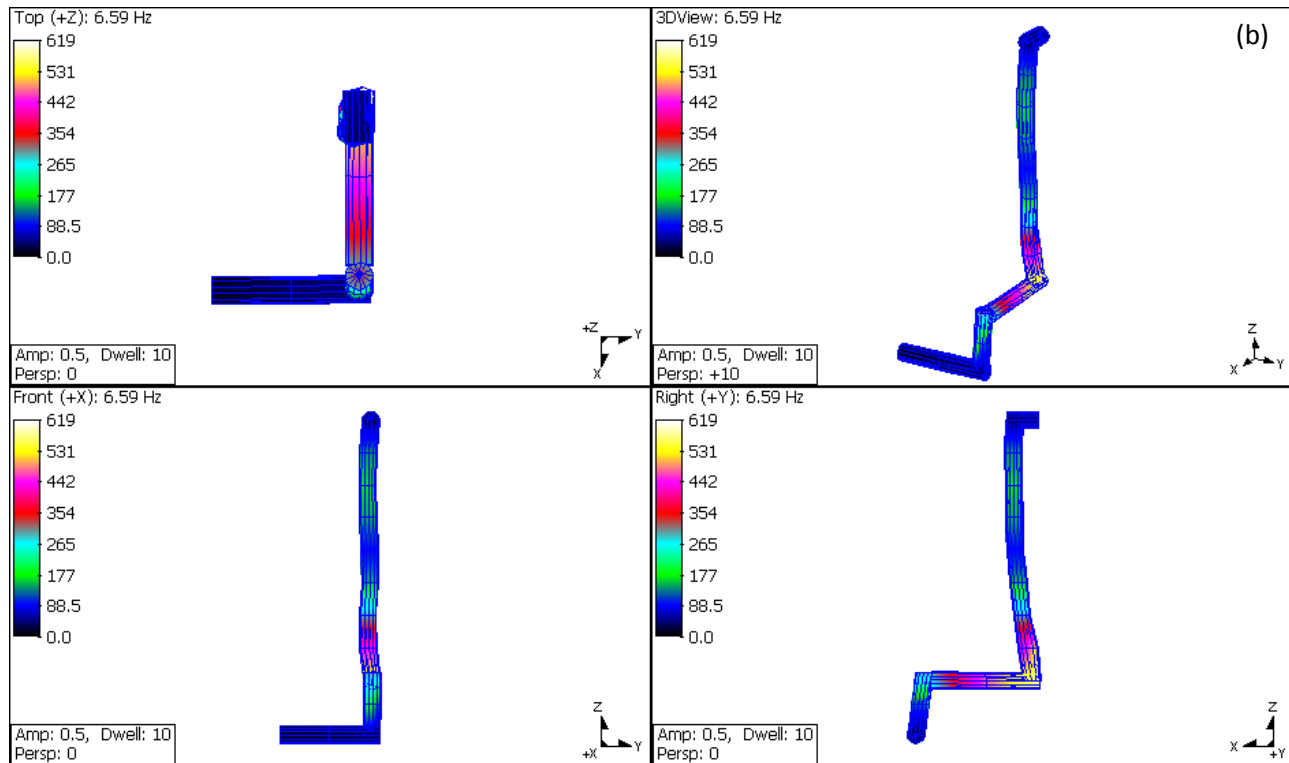

Fig. 6: (a) ODS of amine pipe @ 4.4 Hz, (b) ODS of amine pipe @ 6.59 Hz

### 3.3. Finite Element Modal Analysis

In validating the structural analysis results, i.e. deformation and stress, the FE model was validated through correlating the dynamic characteristics in terms of natural frequencies and their corresponding mode shapes of the piping system obtained by experimental technique, i.e. ODS/OMA and computational technique, FE modal analysis. The flow generates random excitation to the pipe. Thus, the first 2 vibration modes are obtained from the ODS analysis. It helps in generating a reliable model in FEA by comparing the modes between FEA and ODS. FE Modal Analysis reveals the first 2 modes of vibration at 5.5 Hz and 6.6 Hz which are dominated in Y-direction and X-direction respectively shown in Fig. 7. The validated FE model indicates the piping system behaves the same with the actual piping system statically and dynamically and thus structural analyses could be performed to predict the deformation and stress of the piping system.

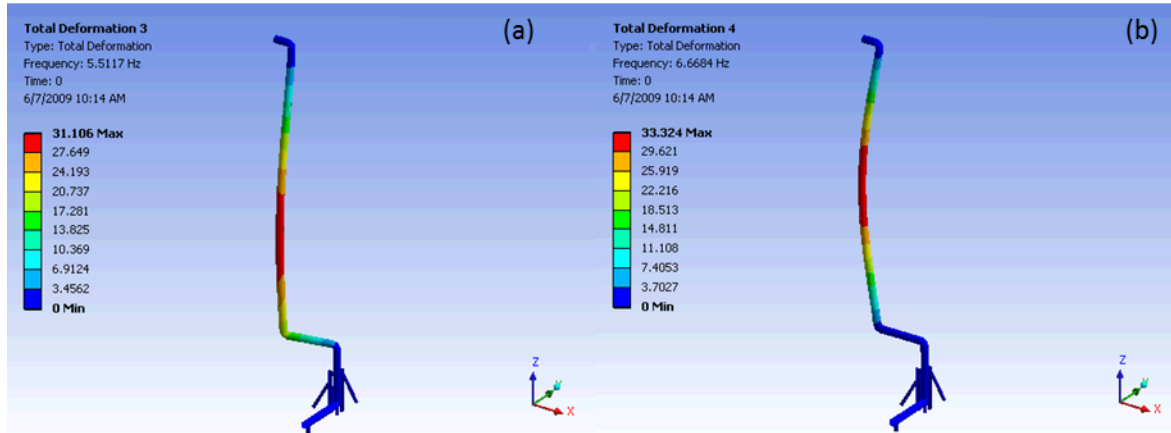

Fig. 7: Pipe bending mode along (a) Y-direction @ 5.5 Hz, (b) along X-direction @ 6.6 Hz

### 3.4. Computational Fluid Dynamics Analysis

There is no resonance issue to cause high vibration at pipe; therefore, it may be caused by flow where steady state CFD analysis takes part to verify this assumption. For CFD analysis, all the flow data, operating parameters and mixture composition were provided by the client base on the idea design as tabulated in Table 1. There were no pre-installed pressure and flow transmitters and thus no actual flow measurement was performed. As the pipe was operating 24/7 without shutting down, there were constraints in access, operation and safety concerns to install any gauges to determine actual flow data. CFD analysis is performed based on the validated FE model. In addition, grid independence test was conducted to validate the consistency and reliability of the CFD result, i.e. pressure which will be used as input loading for structural analysis, i.e. FSI in latter stage. The results show that the number of element used, i.e. 6371 hexahedron elements in fluid domain is sufficient in predicting consistent flow data, i.e. pressure at 0.3056 MPa in the piping system. CFD analysis reveals the forces due to the velocity pressure are at the 4 bends in X, Y and Z directions (Fig. 8). This has caused high vibration at the 4 bends and can be further concluded that the flow is causing the high vibration problem. From CFD analysis, the total head (pressure) pattern generated by the flow is inputted as loading to structure in FSI analysis.

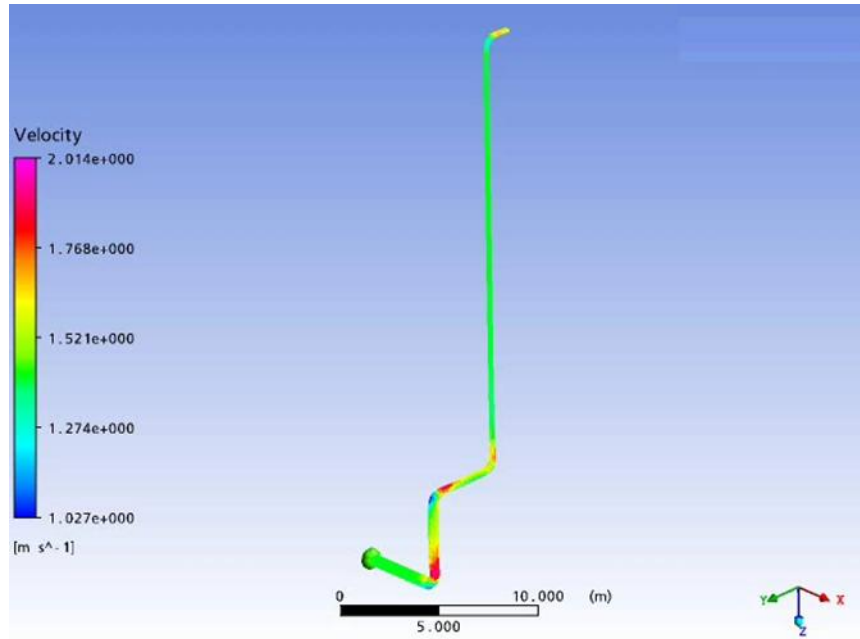

Fig. 8: Fluid flow pattern of amine pipe

### 3.5. Fluid-Structure Interaction Analysis

The total head (pressure) pattern generated in CFD analysis is used as loading to pipe. The deformation (i.e. displacements) and stress contours are obtained and shown Fig.9. FSI analysis gives the static deformation of 23.54 mm at the pipe where the final deformation is the combination of the two modes of deflections in X and Y directions.

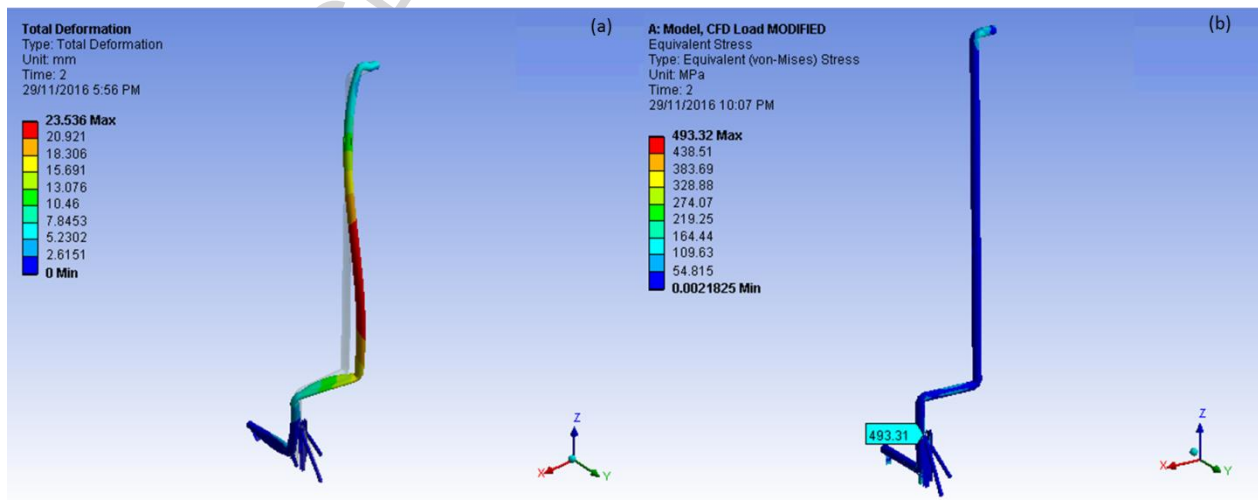

Fig. 9: (a) Deformation of amine pipe, (b) Stress contour of amine pipe



### 3.6. Summary

The flow generates random excitation on the pipe and there is no issue of resonance. Due to this random excitation, ODS analysis revealed the first 2 modes of vibration in pipes. These findings are useful in ascertaining that the FEA model generated is good by comparing the modes between FEA and ODS. Once a good FEA model is achieved, further analyses such as CFD and FSI are performed. CFD analysis revealed that the vibration problem is due to flow. The forces due to the velocity pressure are at the 4 bends in X, Y and Z directions and created high vibration at the bends. The flow generated total head (pressure) pattern which is inputted as loading to structure in FSI analysis. FSI analysis gives the static deformation of the pipe. The total deformation shall be the superimposition of static deformation and dynamic deformation obtained from the ODS analysis. In the absence of cyclic load it is concluded the high vibration is not due to the pipe being dynamically weak. In other words, the problem can be classified as stiffness controlled situation.

## 4. Structural Design Modifications

It is noted that forces along X-direction generate deflection close to the shape of the 1st bending mode in the X-direction and forces along Y-direction generate deflection close to the 1st bending mode in the Y-direction. The final deformation is the combination of the two modes of deflections. Countering these forces at the sources would be a good strategy. The CFD fluid domain, meshing, operating parameters are set consistently same to generate the similar pressure as the input loading in FSI analysis for normal and modified piping system. It is also noted the correlated FE model is continuously used in FSI analysis for determining deformation and stress of the piping system. The consistency in these controlled numerical simulations could ensure comparable data before and after modifications and reduce any discrepancies of the simulated data. The percentage of reduction or increment in deformation and stress level could then be used in evaluating the effectiveness of the proposed design modifications.

### 4.1. Modification 1

Modification 1 proposes two additional supports as shown in Fig. 10 to counter the forces generated by the flow in X and Y directions. The new upper support is used to counter the forces generated along Y-direction whereas the lower support is countering the forces generated in X-direction. The supports are designed with L150 x 150 x 10 mm beams. There are 10 mm thick plates at each beam ends to reduce high stress concentration at the supports (Fig. 11). In this approach, the additional supports are direct welded on the pipe and stripper.

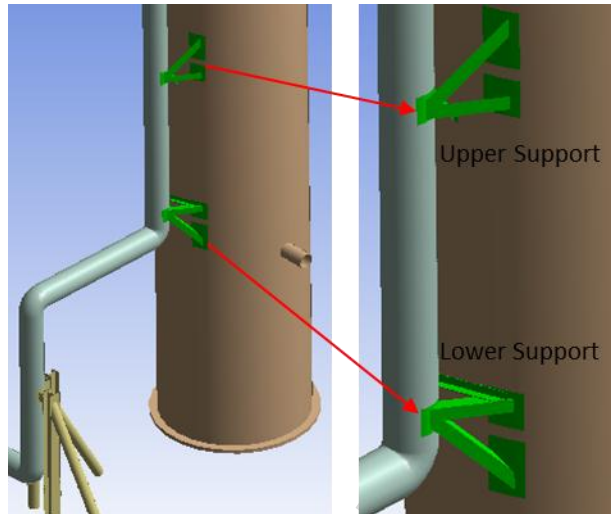

Fig. 10: SDM#1 on amine pipe

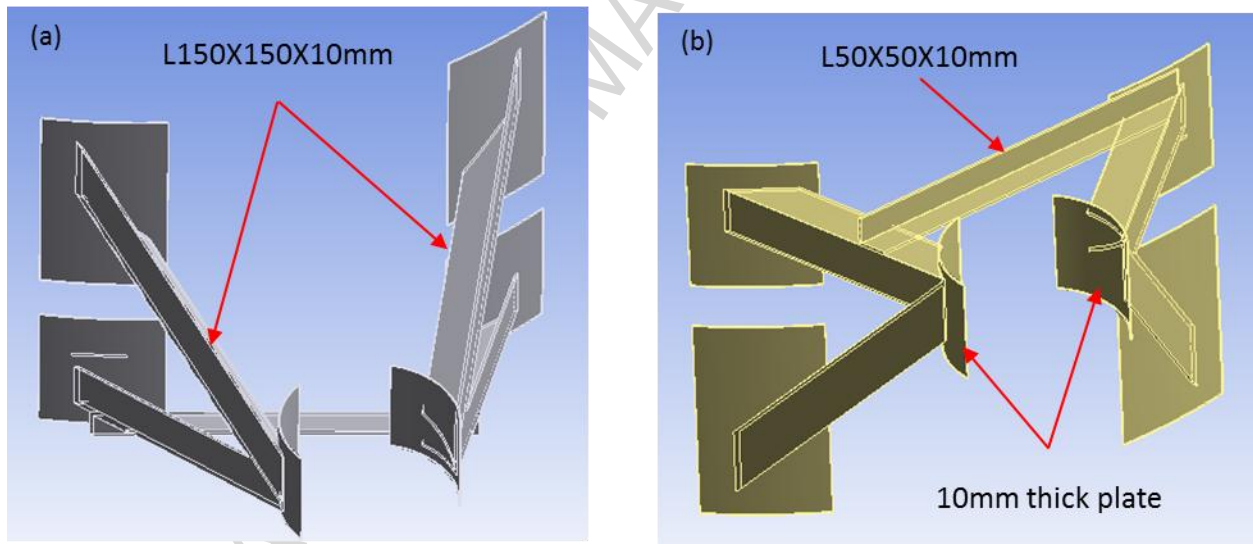

Fig. 11: Details on (a) upper support, (b) lower support

FSI analysis is repeated with the same input parameter on the modified structure to obtain the new deformation (i.e. displacements) and stress contours. FSI reveals that the deflection in FE model drops from 23.54 mm to 4.32 mm which is 82 % of reduction after introducing the two new supports (Fig. 12). In stress analysis, stress level is studied on pipe before and after modification and the new supports. It is noted that there is a minimum change in the stress level and pattern of pipe before and after modification and thus focus is shifted to investigate the stress level on the newly proposed supports. Although high stress concentration occurred at the new upper support (i.e. 175.38 MPa) and lower support (i.e. 131.82 MPa) as shown in Fig. 13 and Fig. 14 respectively, but they were still under the ultimate tension and yield tension limit which are 400 MPa and 248 MPa.

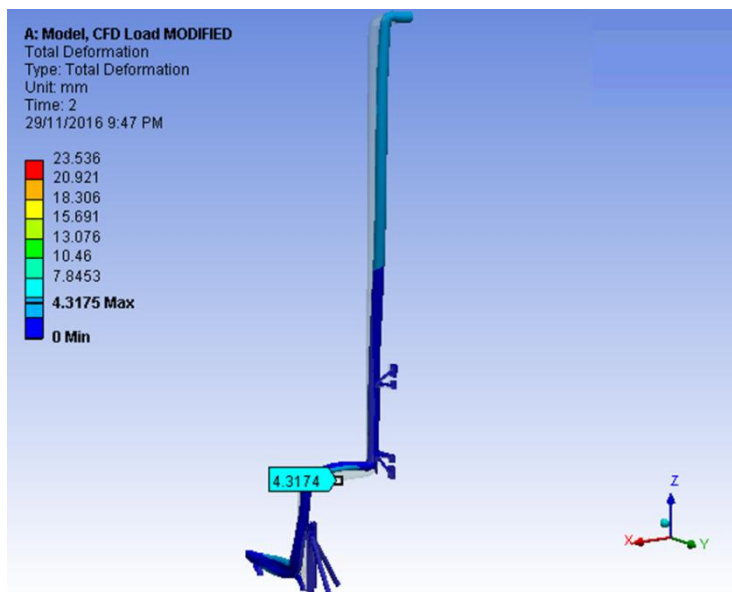

Fig. 12: Maximum deformation of 4.32 mm by SDM#1

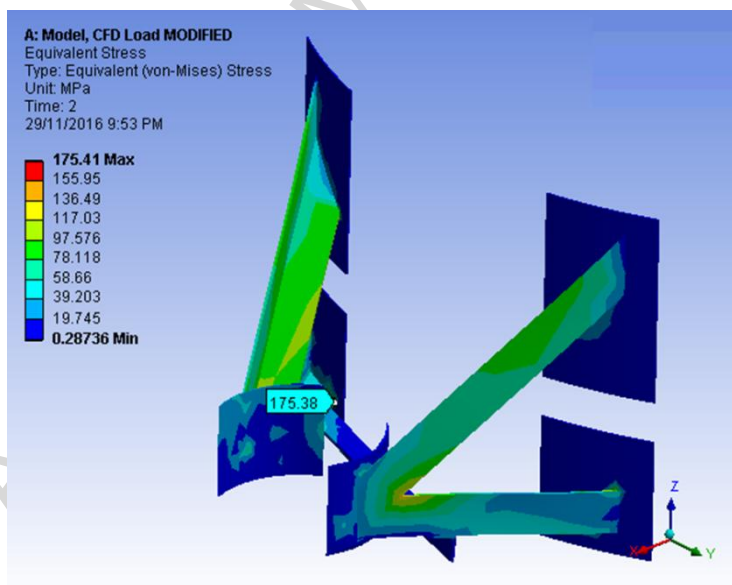

Fig. 13: Maximum stress of 175.38 MPa at new upper support by SDM#1

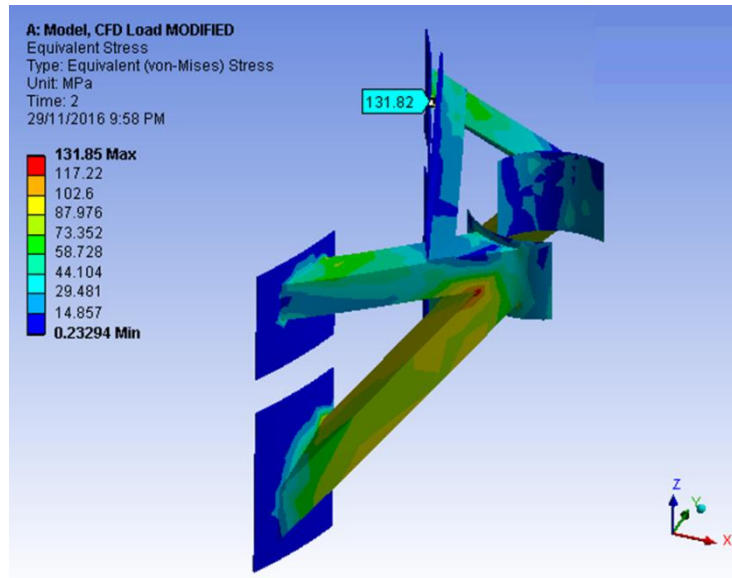

Fig. 14: Maximum stress of 131.82 MPa at new lower support by SDM#1

#### 4.2. Modification 2

The second recommendation proposes the same design of two additional supports to counter the forces generated by the flow in X and Y directions. However, in this approach, clamps are introduced at the both ends of the supports to hold the pipe and stripper instead of direct welding of supports to the pipe and stripper as proposed in SDM#1. Similar to the previous modification, the new upper support is used to counter the forces generated along Y-direction whereas the lower support counters the forces generated in X-direction (Fig. 15).

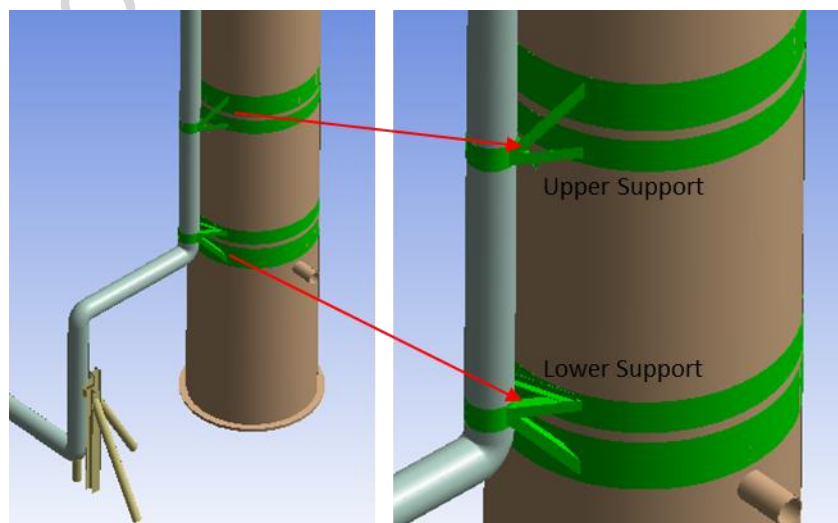

Fig. 15: SDM#2 on amine pipe

FSI analysis is repeated with the same input parameter on the modified structure to obtain the new deformation (i.e. displacements) and stress contours. FSI reveals that the deflection in FE model drops from 23.54 mm to 3.92 mm which is 83 % of reduction after introducing the two new supports which clamped at both the pipe and stripper (Fig. 16). In stress analysis, the stress level is studied on new supports after modification. However, as shown in Fig. 17 and Fig. 18, higher stress concentration occurred at the new upper support (i.e. 189.20 MPa) and lower support (i.e. 195.68 MPa) compared to SDM#1, but they are still under the ultimate tension and yield tension limit which are 400 MPa and 248 MPa.

The summary of both modification approaches in terms of the deformation and equivalent stress is summarized in Table 2. The results are compared to the original piping design to evaluate the integrity and practicality of the proposed modifications.

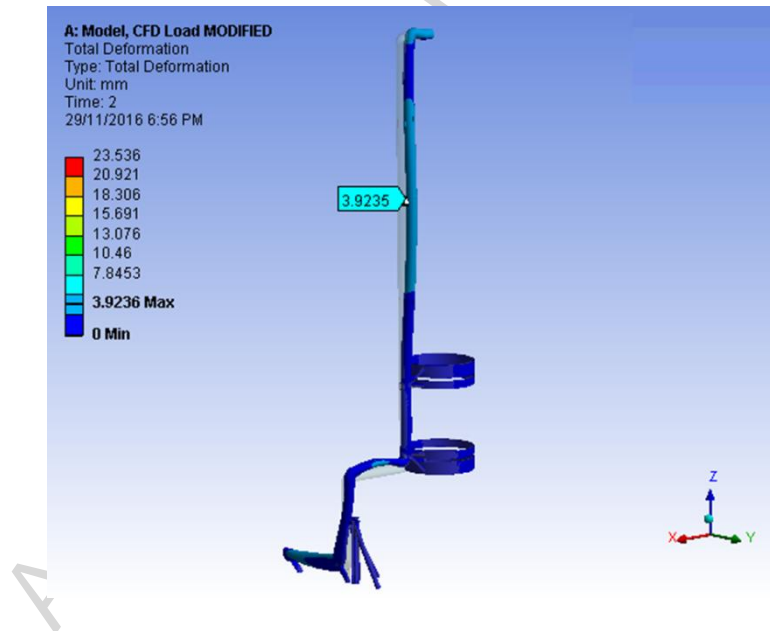

Fig. 16: Maximum deformation of 3.92 mm by SDM#2

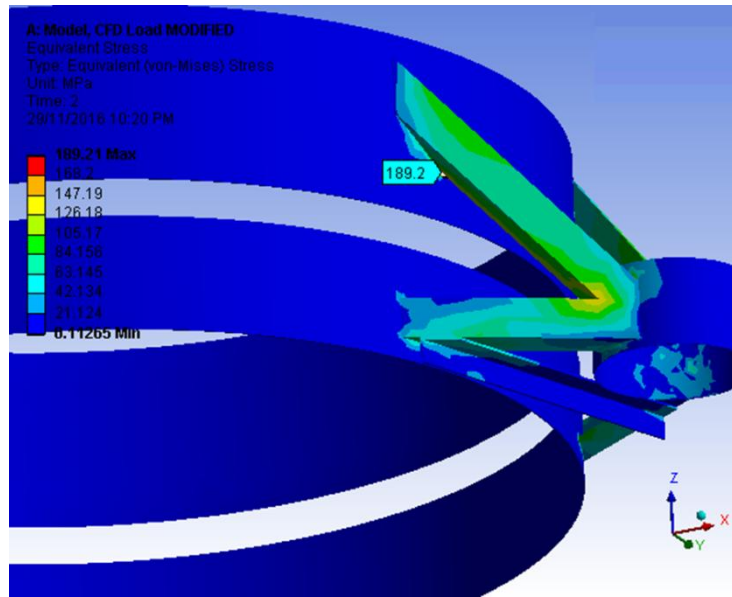

Fig. 17: Maximum stress of 189.2 MPa at new upper support by SDM#2

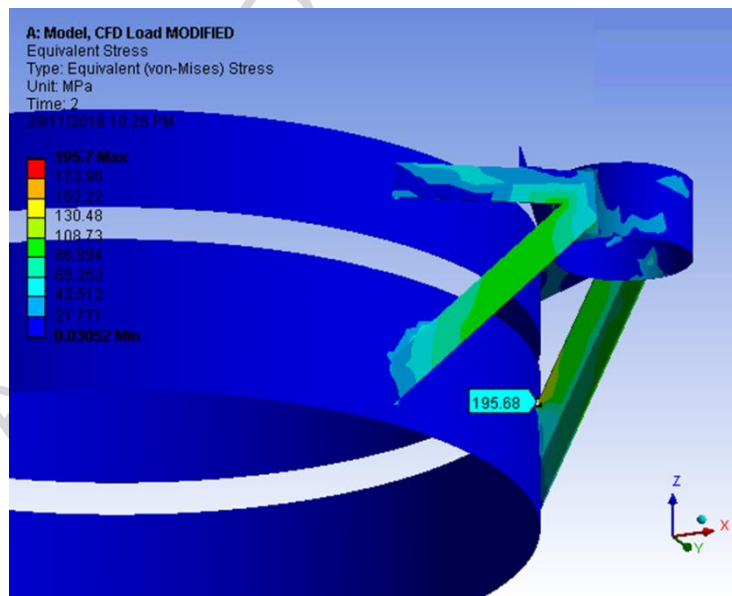

Fig. 18: Maximum stress of 195.68 MPa at new lower support by SDM#2

Table 2: Summary of maximum deformation and maximum stress level from 2 different modifications

SDM	Maximum deformation at amine pipe	Maximum stress at upper support	Maximum stress at lower support
Original	23.54 mm	-	-

SDM#1	4.32 mm	175.38 MPa	131.82 MPa
SDM#2	3.92 mm	189.20 MPa	195.68 MPa

#### 4.3. Precaution for the design of clamping device

It is noted that the clamp must be firmly fixed to the pipe or stripper without any play. Any play between the clamp and pipe or clamp and stripper could increase the stress level at new support. Fig. 19 shows the simulation when there is a play between the clamp and pipe or clamp and stripper created in SDM#2, high stress concentration, i.e. 389.07 MPa is generated at the lower support and it shows more than 100 % increment in stress at the lower support as compared to when the clamping device is intact with the piping system.

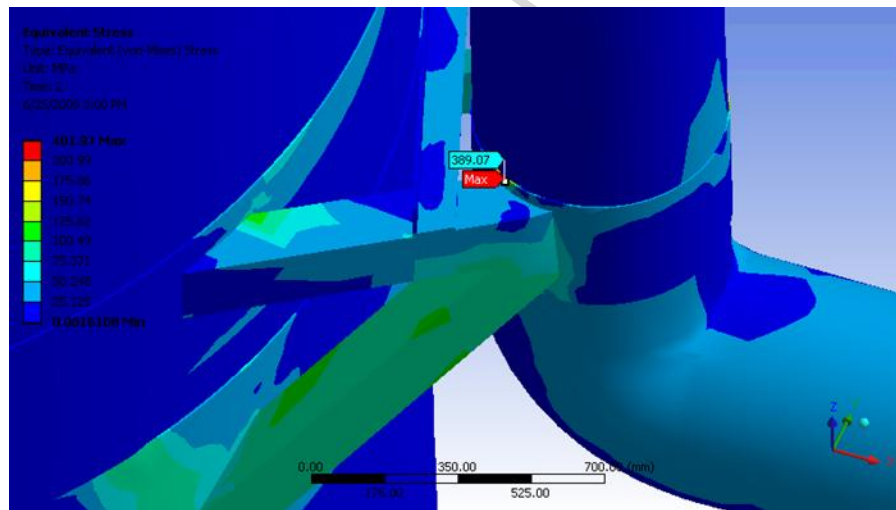

Fig. 19: Maximum stress of 389.07MPa at new lower support with separation on clamps by SDM#2

## 5. Conclusions

Through the hybrid non-destructive testing and assessment approach which consists of experimental and computational analyses, it is concluded that the root cause of high vibration was due to inadequate and weak piping support in countering the forces due to the velocity pressure at the bends. Two additional supports, i.e. upper and lower supports were proposed to counter the X-direction and Y-direction deflection of the piping generated by the flow through direct weld on the pipe and stripper, i.e. SDM#1 and through clamping approach on the pipe and stripper, i.e. SDM#2. The supports were found effective in reducing vibration and it is expected to reduce at least 80% of vibration level from both SDM#1 and SDM#2. Stress concentration occurred at the new proposed upper support and lower support for both proposed SDM#1 and SDM#2 were below the ultimate and yield strength limit respectively. Precaution needs to be taken when fabricating the clamps of SDM#2 where no separation between the contact surfaces during operation is allowed to avoid high stress concentration on the new supports.

## Acknowledgement

The authors wish to acknowledge the financial support and advice given by University of Malaya Research Grant (RP013B-15SUS), Fundamental Research Grant Scheme (FP010-2014A), Advanced Shock and Vibration Research (ASVR) Group of University of Malaya and other project collaborators.

## References

- [1] Blevins RD. Flow-induced vibration. New York: Van Nostrand Reinhold; 1990.
- [2] Chen S-s. Flow-induced vibration of circular cylindrical structures. Washington: Hemisphere Pub. Corp.; 1987.
- [3] Parameshwaran R, Dhulipalla SJ, Yendluri DR. Fluid-structure Interactions and Flow Induced Vibrations: A Review. *Procedia Engineering* 2016;144:1286-93.
- [4] Miwa S, Mori M, Hibiki T. Two-phase flow induced vibration in piping systems. *Progress in Nuclear Energy* 2015;78:270-84.
- [5] Tian J, Yuan C, Yang L, Wu C, Liu G, Yang Z. The vibration analysis model of pipeline under the action of gas pressure pulsation coupling. *Eng Fail Anal* 2016;66:328-40.
- [6] Zou GP, Cheraghi N, Taheri F. Fluid-induced vibration of composite natural gas pipelines. *International Journal of Solids and Structures* 2005;42(3-4):1253-68.
- [7] Dai HL, Wang L, Qian Q, Gan J. Vibration analysis of three-dimensional pipes conveying fluid with consideration of steady combined force by transfer matrix method. *Appl Math Comput* 2012;219(5):2453-64.
- [8] Ashrafizadeh H, Karimi M, Ashrafizadeh F. Failure analysis of a high pressure natural gas pipe under split tee by computer simulations and metallurgical assessment. *Eng Fail Anal* 2013;32:188-201.
- [9] Sierra-Espinoza FZ, García JC. Vibration failure in admission pipe of a steam turbine due to flow instability. *Eng Fail Anal* 2013;27:30-40.
- [10] Zhang T, Zhang YO, Ouyang H. Structural vibration and fluid-borne noise induced by turbulent flow through a 90° piping elbow with/without a guide vane. *Int J Pres Ves Pip* 2015;125:66-77.
- [11] Majid ZA, Mohsin R, Yusof MZ. Experimental and computational failure analysis of natural gas pipe. *Eng Fail Anal* 2012;19:32-42.
- [12] Zhu H, Zhang W, Feng G, Qi X. Fluid-structure interaction computational analysis of flow field, shear stress distribution and deformation of three-limb pipe. *Eng Fail Anal* 2014;42:252-62.
- [13] Kong KK, Noroozi S, Rahman AGA, Dupac M, Eng HC, Ong ZC, Khoo SY, Vinney JE. Non-destructive testing and assessment of dynamic incompatibility between third-party piping and drain valve systems: an industrial case study. *Nondestruct Test Eva* 2014;29(2):154-63.



- [14] Kong KK, Khoo SY, Ong ZC, Eng HC, Ismail Z, Chong WT, Noroozi S, Rahman AGA. Failure analysis of flow-induced vibration problem of in-serviced duplex stainless steel piping system in oil and gas industry. *Mater Res Innov* 2014;18:417-22.
- [15] Rahman AGA, Noroozi S, Dupac M, Al-Attas SMSM, Vinney JE. A hybrid approach for nondestructive assessment and design optimisation and testing of in-service machinery. *Nondestruct Test Eva* 2013;28(1):44-57.
- [16] Trebuňa F, Šimčák F, Huňady R, Pástor M. Identification of pipes damages on gas compressor stations by modal analysis methods. *Eng Fail Anal* 2013;27:213-24.
- [17] Liang Z, Li S, Tian J, Zhang L, Feng C, Zhang L. Vibration cause analysis and elimination of reciprocating compressor inlet pipelines. *Eng Fail Anal* 2015;48:272-82.
- [18] Devriendt C, Steenackers G, De Sitter G, Guillaume P. From operating deflection shapes towards mode shapes using transmissibility measurements. *Mech Syst Signal Pr* 2010;24(3):665-77.
- [19] Dossing O, Staker CH. Operational deflection shapes: background, measurement and applications. *Proceedings of 5th International Modal Analysis Conference* London, UK: 1987; 1987. p. 1372–8.
- [20] Marscher WD, Jen C-W. Use of operating deflection and mode shapes for machinery diagnostics. *Proceedings of 17th International Modal Analysis Conference, Hyatt Orlando Hotel, Kissimmee, Florida, USA: 1999; 1999. p. 2065-71.*
- [21] McHargue PL, Richardson MH. Operating detection shapes from time versus frequency domain measurements. *Proceedings of the 11th International Modal Analysis Conference, Kissimmee, USA: 1993; 1993. p. 581-7.*
- [22] Pascual R, Golinval JC, Razeto M. On-line damage assessment using operating detection shapes. *Proceedings of 17th International Modal Analysis Conference, Hyatt Orlando Hotel, Kissimmee, Florida, USA: 1999; 1999. p. 238–43.*
- [23] Tongue BH. *Principles of vibration*. New York: Oxford University Press; 2002.
- [24] Noroozi S, Rahman AGA, Dupac M, Ong ZC, Mohd al-Attas MBS. Condition monitoring and diagnostic of an extruder motor and its gearbox vibration problem (an industrial case study). *Insight - Non-Destructive Testing & Condition Monitoring* 2016;58(3):101-7.
- [25] Wachel JC. *Piping Vibration and Stress*. Vibration Institute, Machinery Vibration Monitoring and Analysis Seminar, New Orleans, LA: 1981; 1981. p. 1-9.

#### Highlights

- High vibration problem experienced by amine pipe was investigated
- Non-destructive testing approach was used to assess structural integrity of the pipe
- Root cause of high vibration was due to inadequate and weak piping support
- Recommendations in rectifying the high vibration issue were proposed

ACCEPTED MANUSCRIPT